

DESK DRAWER

1. Place the desk SIDES in the assembly jig with slotted edges up.
2. Slide the BACK into the grooves at the back of the SIDES.
3. Slide the TOP into the female dovetails. Be sure to keep the groove edges up, and the rabbet toward the inside of the cabinet.

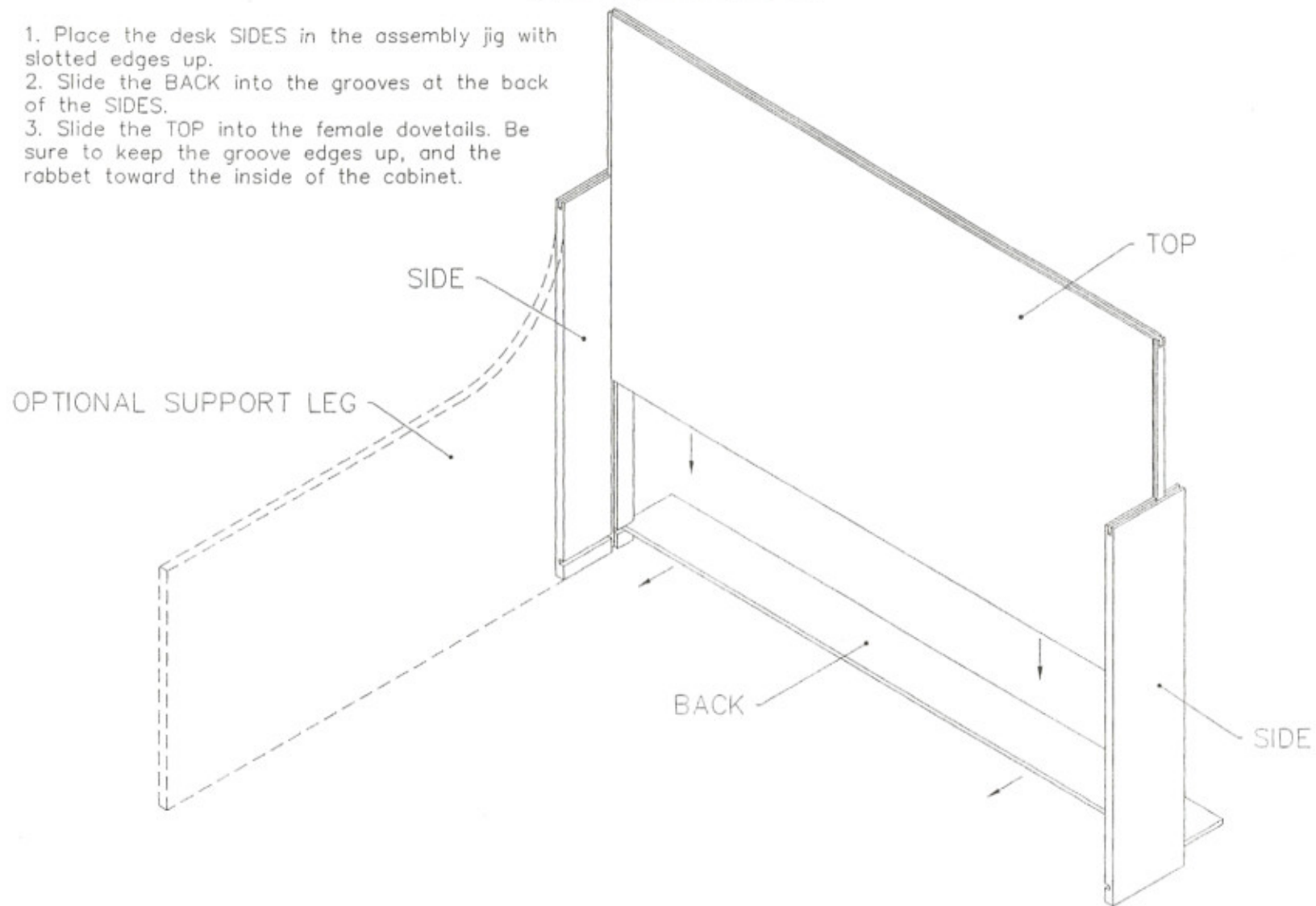

DESK DRAWER

4. After inserting splines into FRONT FRAME, spread glue into the slotted edges of the SIDES and TOP the FRONT FRAME can now be attached. Match up the splines in the FRONT FRAME to the slots in the cabinet box. Tap the FRONT FRAME on with a rubber mallet, making sure the cabinet FRONT FRAME is pressed firmly onto the cabinet box.

5. To attach HANGER CLEAT see page #3.

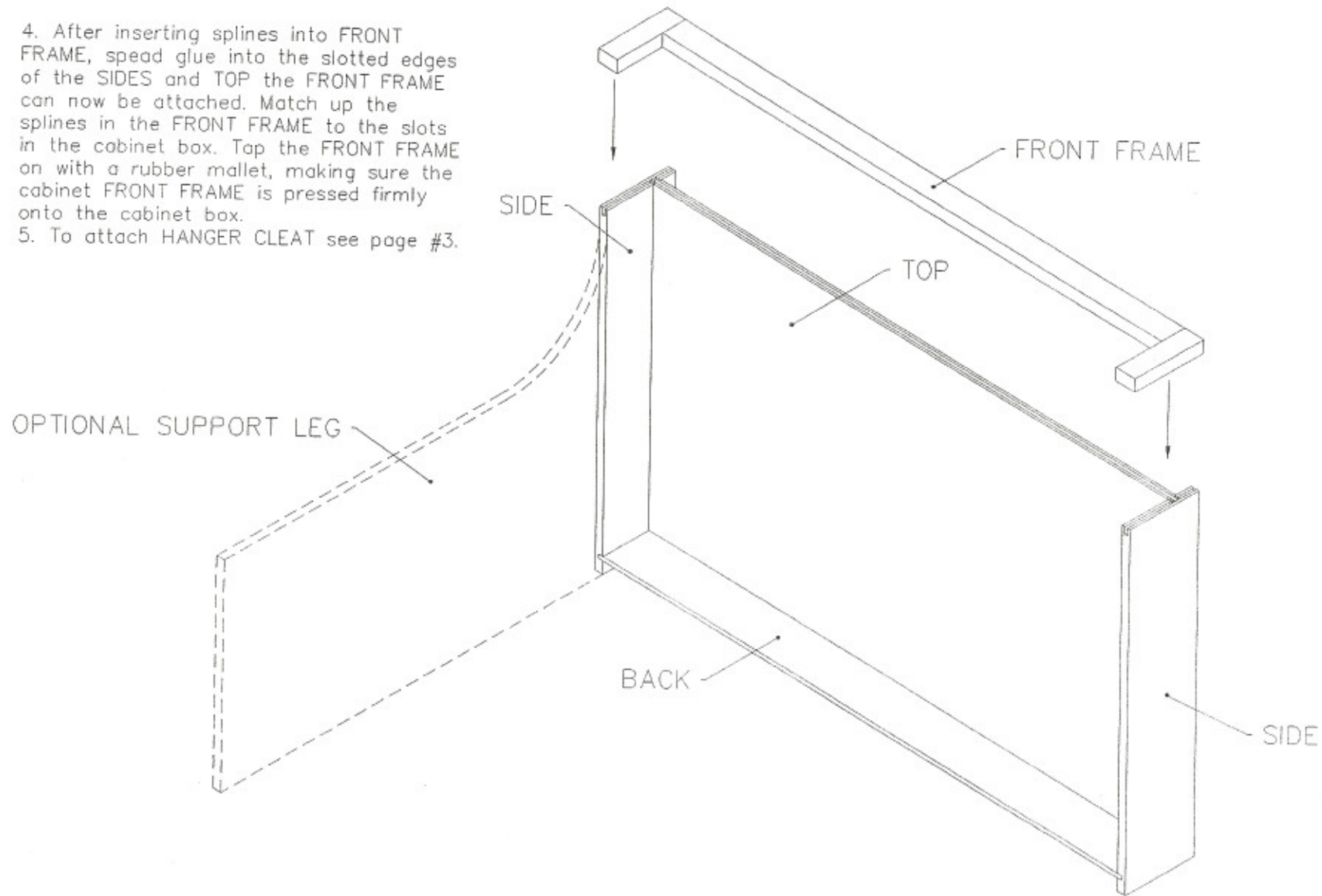

DESK DRAWER

6. Mount DRAWER CLEAT to SIDE with the front edge tight against the FRONT FRAME. Mount CABINET MEMBER to DRAWER CLEAT.
7. Attach DRAWER MEMBER to DRAWER BOX.

