

DESK DRAWER SLIDE INSTALLATION

1. Mount DRAWER CLEAT to SIDE with the front edge tight against the FRONT FRAME. Mount CABINET MEMBER to DRAWER CLEAT.
2. Attach DRAWER MEMBER to DRAWER BOX.

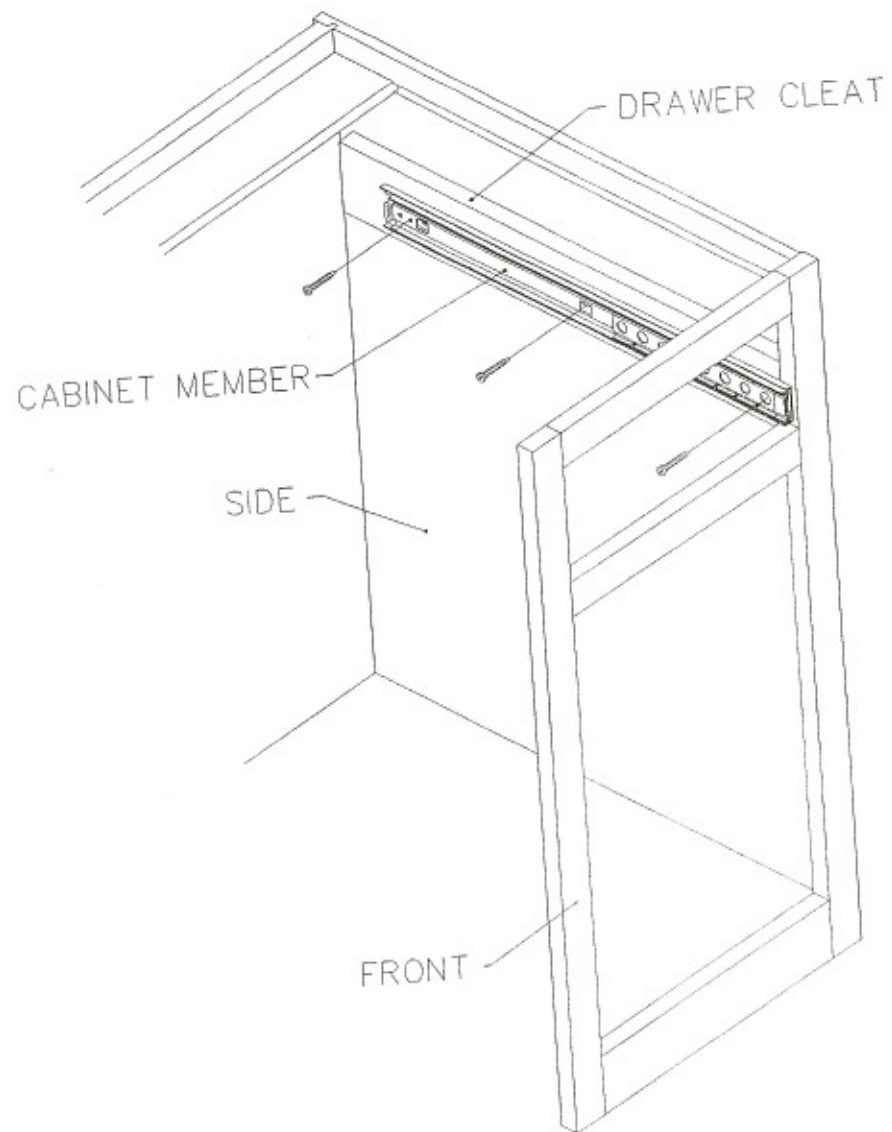
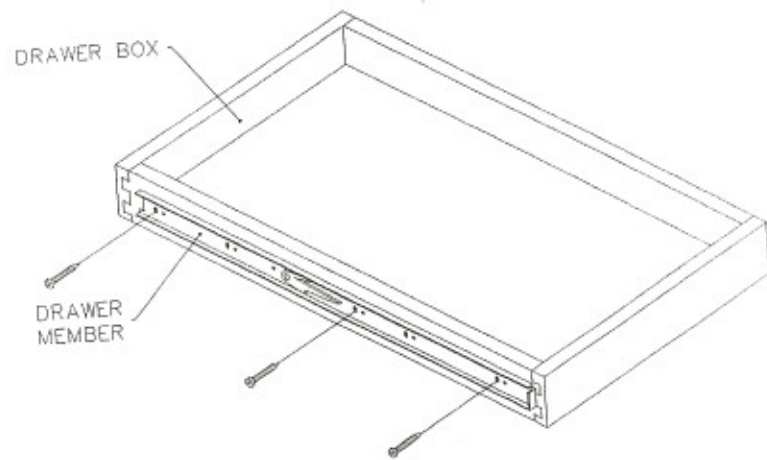

DESK BASE 2 & 3 DRAWER SLIDE INSTALLATION

1. Mount DRAWER CLEAT to SIDE so that DRAWER MEMBER can be attached with screws. It is recommended that the DRAWER CLEAT be glued to the cabinet SIDE. Mount CABINET MEMBER to DRAWER CLEAT.
2. Attach DRAWER MEMBER to DRAWER BOX.

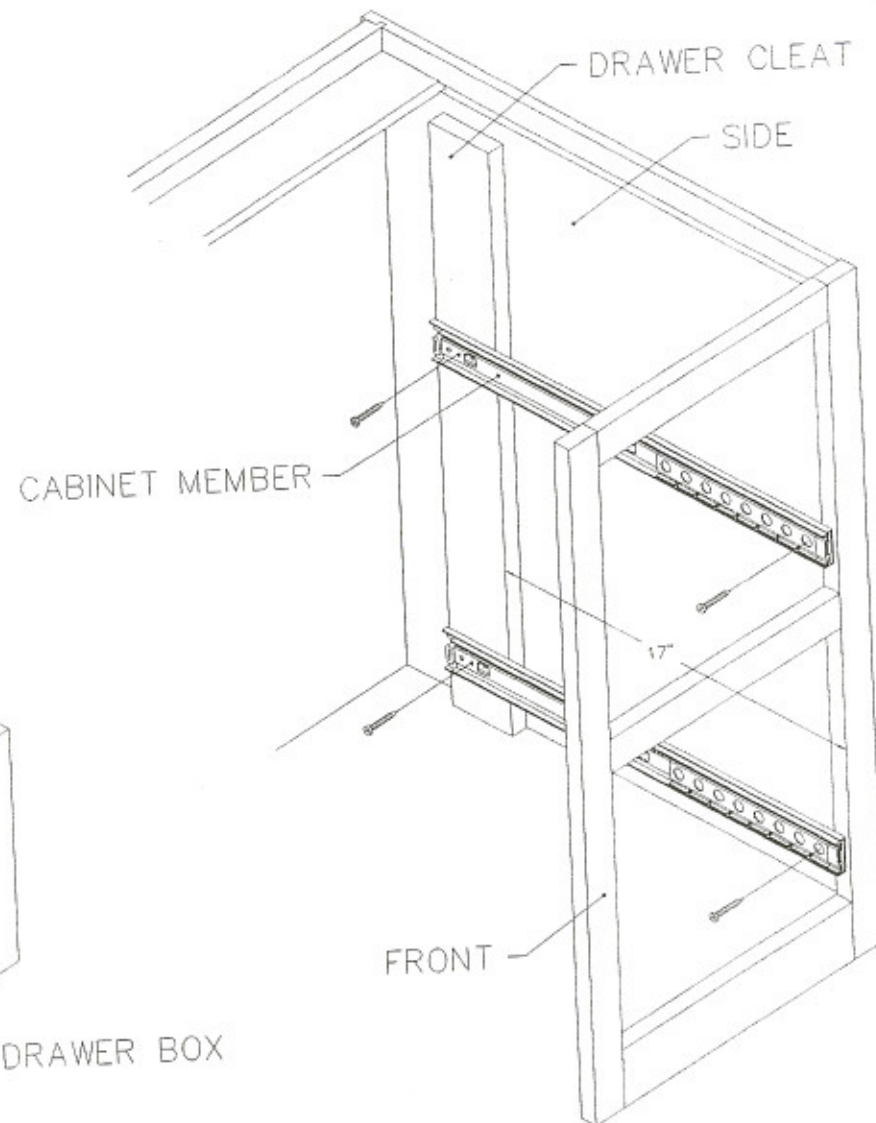
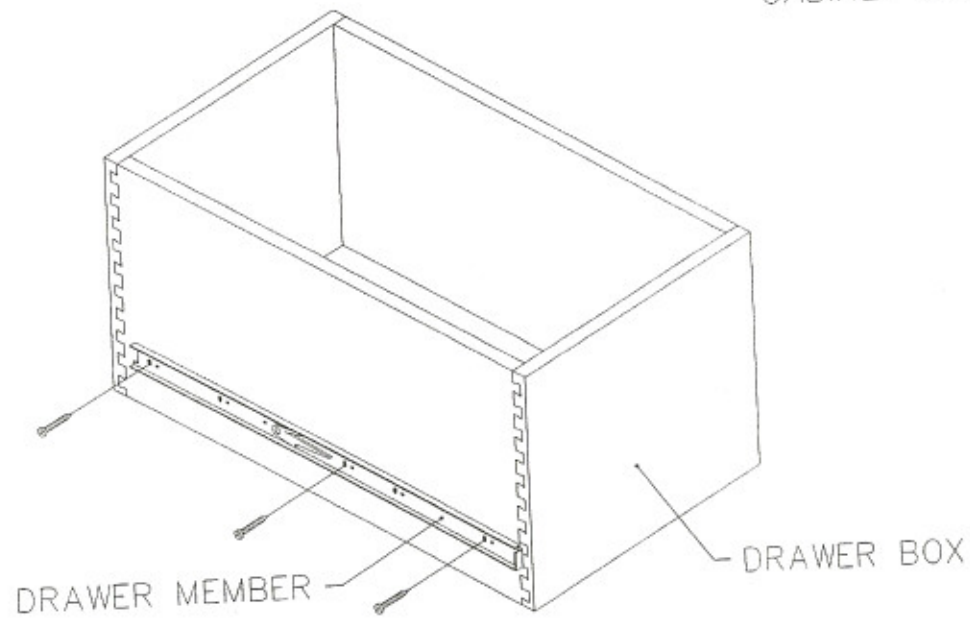

LATERAL FILE 2 DRAWER SLIDE INSTALLATION

1. Mount DRAWER CLEATS to SIDE so that DRAWER MEMBER can be attached with screws. It is recommended that the DRAWER CLEAT be glued to the cabinet SIDE. One set of CLEATS should be mounted tight against inside of FRONT FRAME. Position the second set approximately 14" behind the back of the FRONT FRAME.

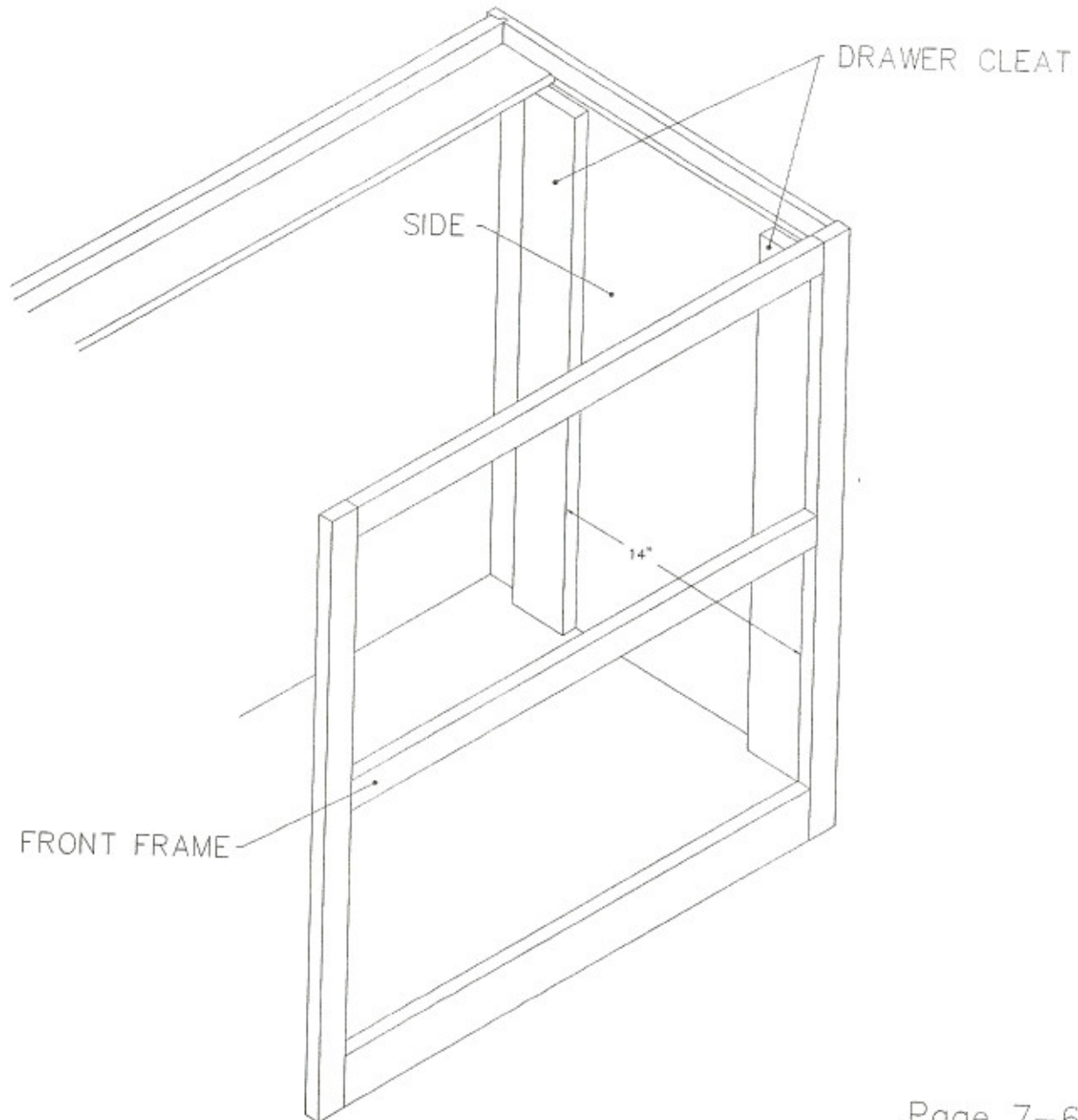

LATERAL FILE 2 DRAWER SLIDE INSTALLATION (cont.)

2. Mount CABINET MEMBER to DRAWER CLEATS. Refer to instructions in slide package for specific placement information.
3. Mount DRAWER MEMBER to DRAWER BOX.
4. Cut CONNECTING ROD to length as specified by slide manufacturer and install between CABINET MEMBERS.
5. For additional installation and adjustment instructions see manufacturer's instructions supplied with slide pack.

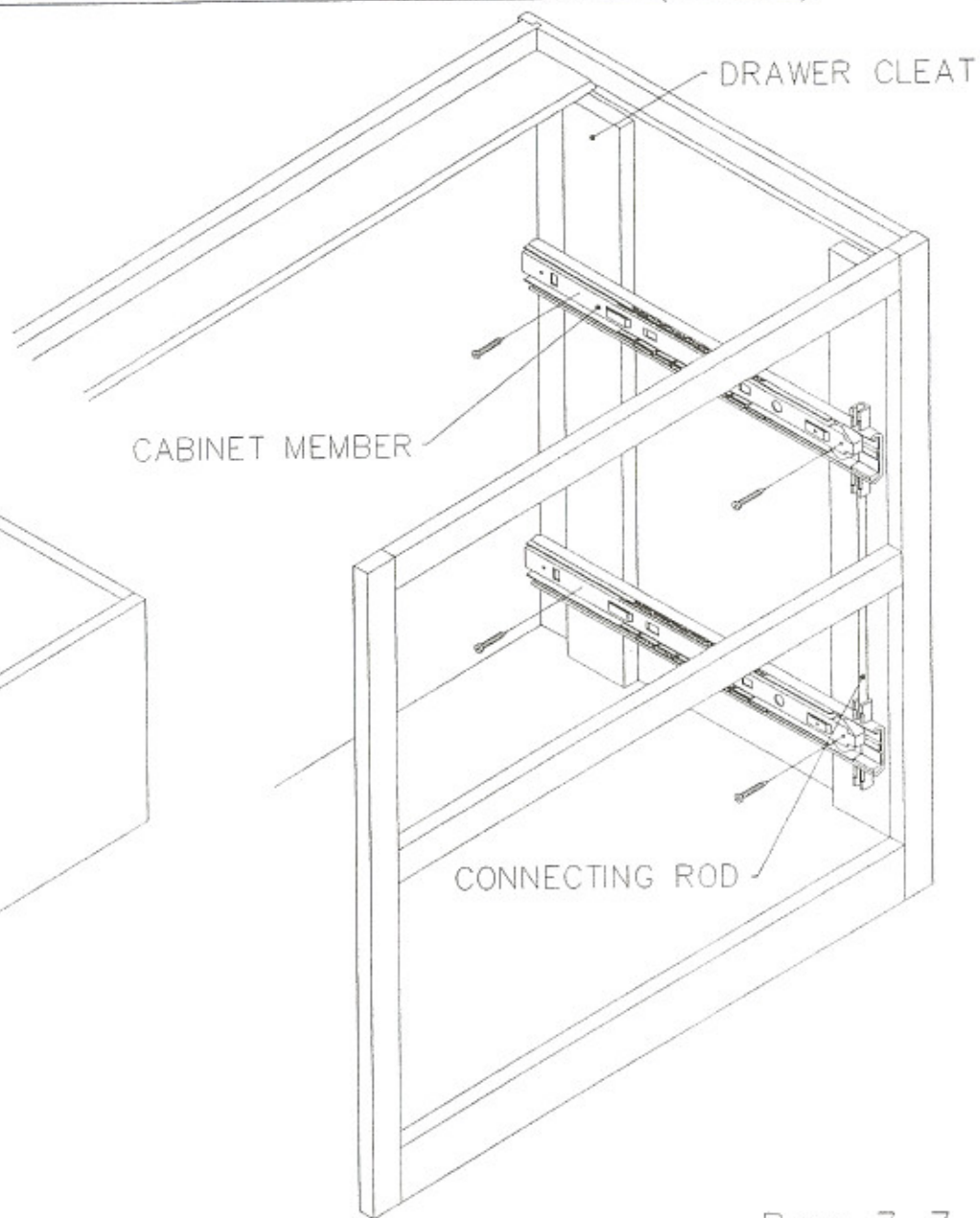
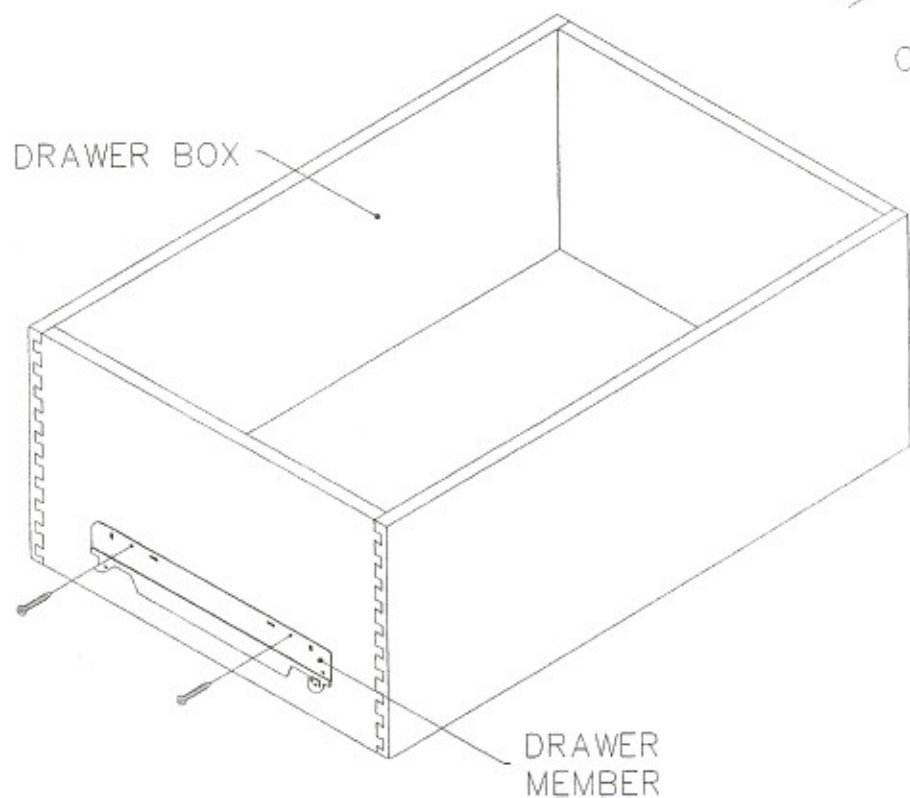

UNDERMOUNT DRAWER SLIDE INSTALLATION – INSET

CABINET ASSEMBLY

1. Mount REAR BOOT on end of CABINET MEMBER. Insert tabs on the back of the REAR BOOT into the pre-drilled holes in the CABINET BACK.

2. Fasten the CABINET MEMBER to the FRONT FRAME using the screws provided.

NOTE: For cabinets with non-overlay drawer fronts, install a 3/4" thick SPACER behind FRONT FRAME and mount CABINET MEMBER to block.

3. Secure REAR BOOT to CABINET BACK using the screws provided.

DRAWER ASSEMBLY

1. The DRAWER MEMBERS should be mounted after the DRAWER BOX is assembled.

NOTE: Back of DRAWER BOX must be notched before attaching DRAWER MEMBER.

2. Place the DRAWER MEMBER onto the bottom of the box and press TEETH firmly into bottom groove. The front of the DRAWER MEMBER should be flush with the front of the DRAWER BOX. Fasten the slide to the DRAWER BOX using 2 screws as shown.

